



Hydrotherapy Benefits

The Companion® Underwater Treadmill brings you top-of-the-line quality surgical stainless steel, tempered glass, and dual doors at a price only previously seen for plastic and plexiglass models. Included with the system are the treadmill chamber, plant pack, sand filter, and water storage tank.

01

Custom Features

- 316 surgical stainless steel and tempered glass
- Attached push-button controls
- Easy-to-clean system
- Speeds up to 7mph
- Reversible doors
- Temperature control
- Dedicated waste drain for accidents
- Dual door walk-through design
- Runs without water
- Belt runs in either direction
- Stride length and water height rulers
- 360° views for therapist and patient

02

Patient Benefits

- Improve range of motion and mobility
- Minimize weight on arthritic joints or during post-op recovery
- Enhance cardiovascular function and performance
- Accelerate return to function after injury
- Provide stability and confidence while exercising
- Intensify conditioning or boost weight loss

03

Practice Benefits

- Offer a unique service compared with your competitors while generating a recurring revenue stream
- Provide additional options for pain management and non-surgical issues
- Create fitness and weight-loss programs for patients



Underwater Treadmill

Treadmill chamber

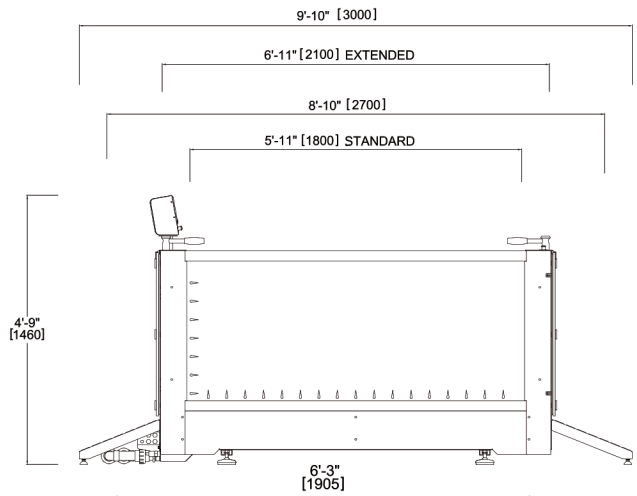

Plant pack and storage tank

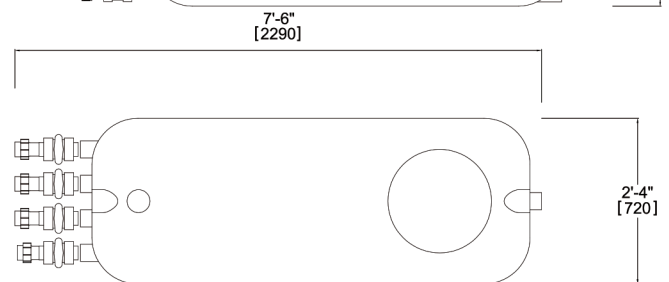
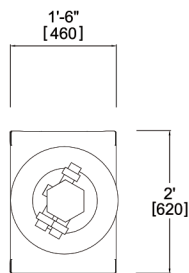
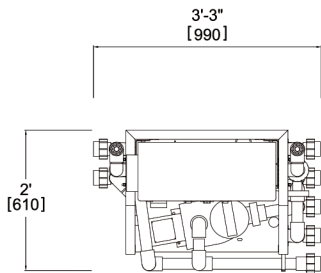
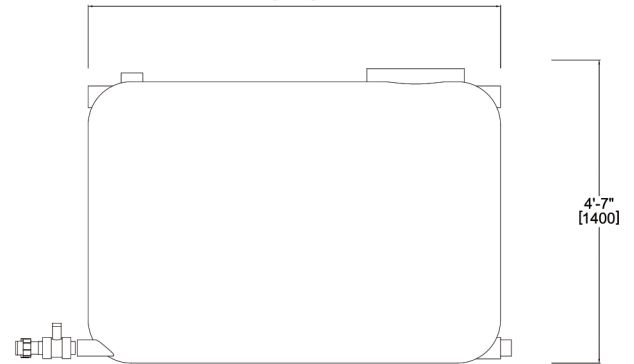
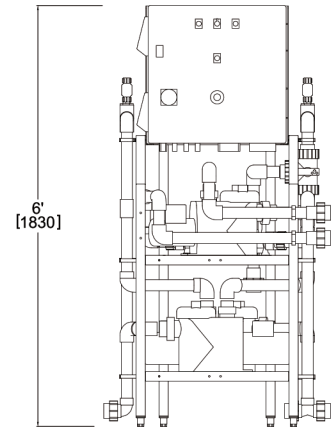

Typical layout

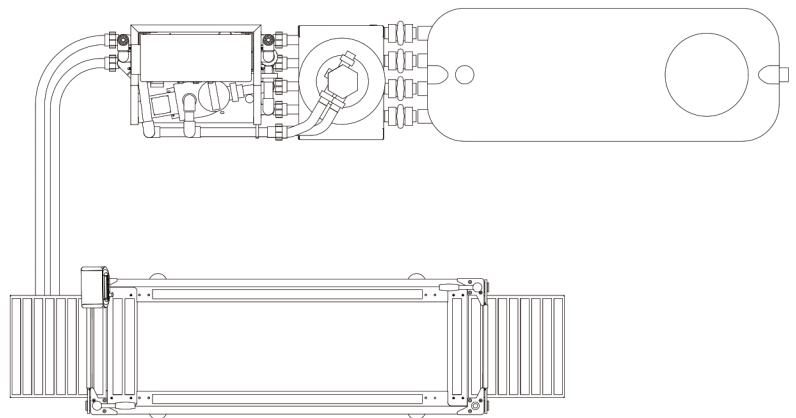

04 Specifications

- 220VAC, 30Amp, 60Hz single phase outlet
- Cold water line
- 2" dedicated waste drain that handles 65 gallons/min
- Floor loading of 3800 lbs
- Storage tank holds 400 gallons
- Fill/Empty time of 3½ min
- Usable belt length
 - Standard 54" x 19"
 - Extended 66" x 19"

